



Power Sensing Solutions for a Better Life

IMU280ZA

INERTIAL MEASUREMENT SYSTEM

The MEMSIC IMU280ZA is a low cost miniature fully-calibrated inertial measurement system designed for demanding embedded applications that require a complete dynamic measurement solution in a robust low-profile package. The IMU280ZA provides a standard SPI bus for cost-effective board-to-board communications.



Cabin Leveling



Antenna Stabilization

The MEMSIC IMU280ZA integrates highly-reliable MEMS 6DOF inertial sensors (optional 3-axis magnetic sensors) in a miniature factory-calibrated module to provide consistent performance through the extreme operating environments in a wide variety of dynamic control and navigation applications.

Applications

- Cabin Leveling
- Platform Stabilization
- Unmanned Vehicle Control
- Robotics Control

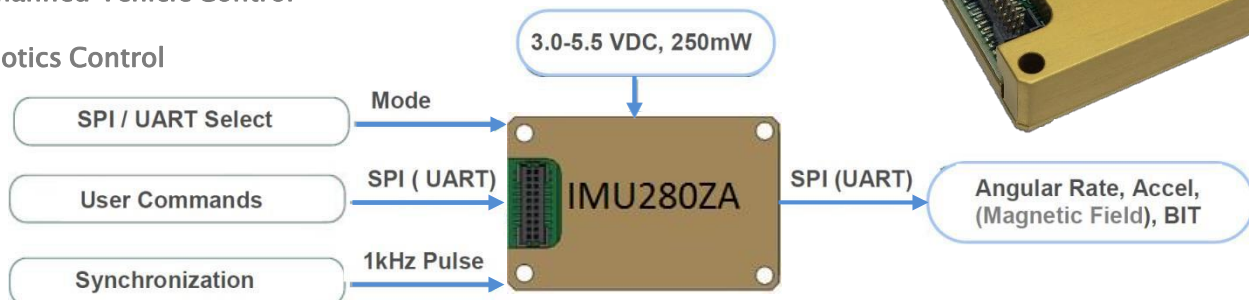

Features

- Complete 6DOF Inertial System
- Optional 3-Axis Magnetometer
- Standard and High Range Options
- SPI (or UART) Interface
- Update Rate, 1Hz to 200Hz
- 1KHz Clock Sync Input
- Miniature Package, 24 x 37 x 9.5 mm
- Lightweight < 17 g
- Low Power Consumption < 250 mW
- Wide Temp Range, -40C to +85C
- High Reliability, MTBF > 50k hours



Performance IMU280ZA (-200,-209,-400,-409)

Angular Rate	
Range: Roll, Pitch, Yaw (°/sec)	± 200 (± 400 High Range Model)
Bias Instability (°/hr) ^{1,2}	< 20
Bias Stability Over Temp (°/sec) ²	< 2.0
Resolution (°/sec)	< 0.02
Scale Factor Accuracy (%)	< 0.2
Non-Linearity (%FS)	< 0.2
Angle Random Walk (°/√hr) ²	< 1.5
Bandwidth (Hz)	5-50 (user-configurable)
Acceleration	
Range: X, Y, Z (g)	± 4 (± 8 High Range Model)
Bias Instability (mg) ^{1,2}	< 0.05
Bias Stability Over Temp (mg) ²	< 15
Resolution (mg)	< 0.5
Scale Factor Accuracy (%)	< 0.2
Non-Linearity (%FS)	< 0.2
Velocity Random Walk (m/s/√hr) ²	< 0.1
Bandwidth (Hz)	5-50 (user-configurable)
Magnetic Field	
Range: X, Y, Z (Gauss)	± 4
Resolution (mGauss)	< 5
Noise Density (mGauss /√Hz) ²	< 1
Bandwidth (Hz)	5

Specifications

Environment	
Operating Temperature (°C)	-40 to +85
Non-Operating Temperature (°C)	-55 to +105
Enclosure	Aluminum (Gold Anodized)
Electrical	
Input Voltage (VDC)	3.0 to 5.5
Power Consumption (mW)	< 250
Digital Interface	SPI or UART (user-configurable)
Output Data Rate	1Hz to 200Hz (user-configurable)
Input Clock Sync	1kHz Sync Pulse
Physical	
Size (mm)	24.15 x 37.7 x 9.5
Weight (gm)	< 17
Interface Connector	20-Pin (10 x 2) 1.0 mm pitch header

Ordering Information

Model	Description
IMU280ZA-200	6DOF OEM Standard Range IMU
IMU280ZA-400	6DOF OEM High Range IMU
IMU280ZA-209	9DOF OEM Standard Range IMU
IMU280ZA-409	9DOF OEM High Range IMU
EVAL-KIT DMU280ZA-200	9DOF Standard Range DMU380ZA Evaluation Kit
EVAL-KIT DMU280ZA-400	9DOF High Range DMU380ZA Evaluation Kit

This product has been developed exclusively for commercial applications. It has not been tested for, and makes no representation or warranty as to conformance with, any military specifications or its suitability for any military application or end-use. Additionally, any use of this product for nuclear, chemical or biological weapons, or weapons research, or for any use in missiles, rockets, and/or UAV's of 300km or greater range, or any other activity prohibited by the Export Administration Regulations, is expressly prohibited without the written consent and without obtaining appropriate US export license(s) when required by US law. Diversion contrary to U.S. law is prohibited. Specifications are subject to change without notice.

¹Allan Variance Curve, constant temperature. ²1-sigma error.

NAV-VIEW Configuration and Display Software

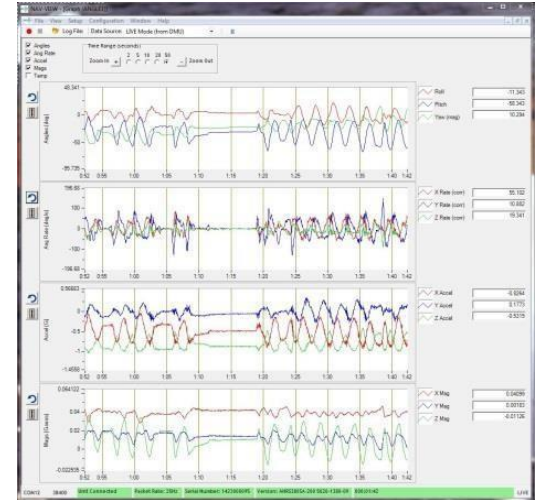

NAV-VIEW provides an easy to use graphical interface to display, record, playback, and analyze all of the IMU280ZA Inertial Measurement System parameters.

NAV-VIEW can also be used to set a wide range of user-configurable fields in the IMU280ZA to optimize the system performance for highly dynamic applications.

NAV-VIEW software is available for download from MEMSIC's website at: www.memsic.com/support

Other Components

The DMU280ZA evaluation kits include an AHRS280ZA, evaluation board, and USB cable allowing direct connection to a PC for use with NAV-VIEW display and configuration software.

Support

For more detailed information please refer to the DMU280ZA Series User's Manual available online at: www.memsic.com/support